

GODZILLA

Contact Us:
Whatsapp: +8613995696053
Email: sales@CGDI SHOP. com
Website: <https://www.cgdi shop. com/>

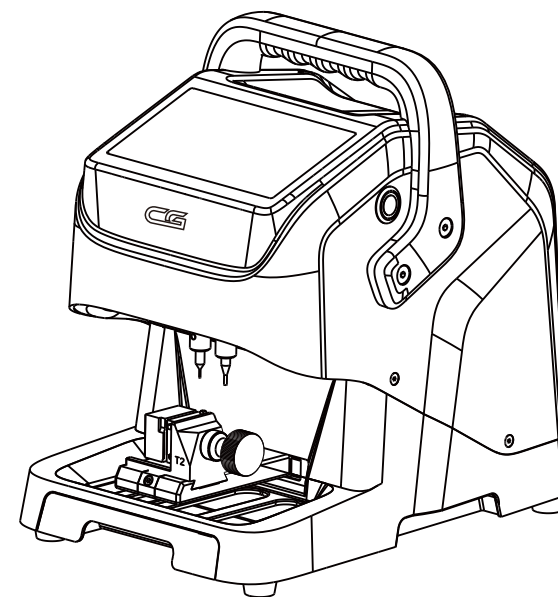

GODZILLA **Smart Key Cutting Machine**



USER MANUAL

Please read instruction carefully before using.

©1.0

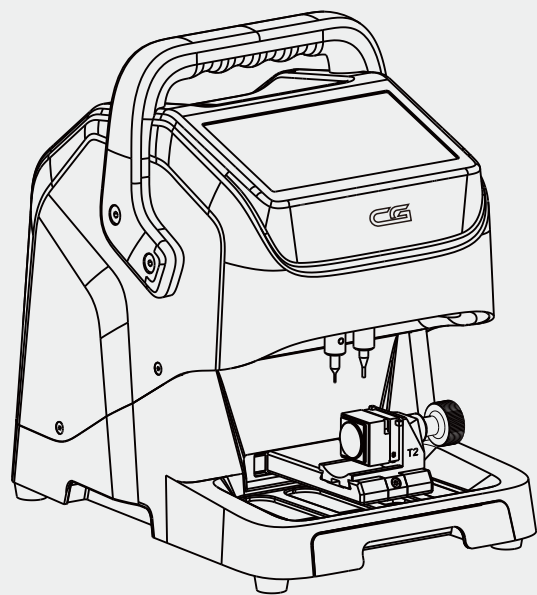

CG-007
Smart Key Cutting Machine

Disclaimer and Limitation of Liability

All information and illustrations in the manual are the latest information. Shenzhen Changguang Technology Co., Ltd. reserves the right to make changes without notice.

Our company does not bear any direct, indirect, special, incidental damages or any indirect economic damages.

Note:

Before operating or maintaining the equipment, please read this manual carefully, especially the safety precautions and warnings.



CATALOGUE

1. Safety Precautions.....	02
2. Product Description.....	03
2.1 Features	03
2.2 Product Structure Diagram.....	04
2.3 Product List.....	05
2.4 Product Specifications.....	07
3. Installation instructions.....	09
3.1 Support plate removal.....	09
3.2 Milling cutter and probe installation.....	10
3.3 Milling cutter and probe Disassembly.....	11
3.4 Fixture.....	12
3.5 Fixture installation.....	13
4. Operation instructions.....	14
4.1 Fixture offset detection.....	14
4.2 Leveling the changed height.....	17
4.3 Leveling the changed height.....	19
4.4 Car Database.....	22
4.5 Universal Key Copy.....	24
4.6 Cut By Bitting.....	26
4.7 All Key Lost Query.....	30
4.8 Missing Tooth Query.....	32
5. Online upgrade.....	34
5.1 Wi-Fi connection.....	34
5.2 Software online upgrade.....	35
5.3 Firmware upgrade online.....	37
5.4 Database online upgrade.....	37
6. Maintenance.....	38
6.1 Maintenance instructions.....	38
7. Warranty.....	39

1. Safety Precautions

In order to ensure the safety of the operator, and to avoid damage to the machine/key and property loss, the operator must carefully read this operation manual before using the machine and observe the following safety precautions:

- ☀️ **Please take out the device support plate when using.**
- ☀️ **Always operate the machine in a safe environment.**
- ☀️ **During operation, please wear goggles that comply with ANSI standard.**
- ☀️ **During the operation of the machine please do not keep clothes, hair, hands, and other tools near the key cutting area.**
- ☀️ **Do not place the device in a humid, dusty, or direct sunlight environment for a long time.**
- ☀️ **Do not have heavy pressure, fading, immersion device and other behaviors.**
- ☀️ **If not used for a long time, it is recommended to unplug the power supply.**
- ☀️ **Please use original lithium battery or power adapter.**
- ☀️ **In the event of an abnormality, turn off the power immediately.**

2. Product Description

Godzilla Key Cutter is easy to carry with super powerful and advanced Design. It is a new generation of key processing device tailored for global locksmiths. It is equipped with a 7.0-inch LCD operation screen, which is easy to operate and can be quickly and accurately copy all kinds of car keys.

2.1 Features

Godzilla Key Cutter has following features:

- 👍 7 inch LCD operation screen.
- 👍 Portable and exquisite, built-in large capacity lithium battery, ultra long continuous cutting ability.
- 👍 Standard dual fixture T1 / T2.
- 👍 Support external milling / internal milling, etc.
- 👍 All aluminum structure.
- 👍 High precision imported lead screw with high cutting efficiency.
- 👍 High-rigidity cross guide rail for smoother operation.
- 👍 Support multiple languages.
- 👍 Automatic network update .











Note:







Lithium battery is optional purchase product.

2.2 Product Structure Diagram



2.3 Product List

Name	Picture	Quantity	Configuration	Description
Godzilla Key Cutter Host		1	Standard	Machine body
T1 Fixture		1	Standard	Outside open key Fixture
T2 Fixture		1	Standard	Key Fixture
T3 fixture (optional)		1	Optional	Ford FO21 Citroen SX9 fixture
1.5mm Milling cutter		1	Standard	Cutting tool (φ2.5*φ6*40L)
2.5mm Milling cutter		1	Standard	Cutting tool (φ2.5*φ6*40L)
1.0mm Probe		2	Standard	Detection tool (φ1.0*φ6*40L)
2mm inner hexagon spanner		1	Standard	Replace probe, milling cutter and T1 Fixture
3mm inner hexagon spanner		1	Standard	Fixture installation tools
5mm inner hexagon spanner		1	Standard	Removal tool
Cleaning brush		1	Standard	Clean up debris

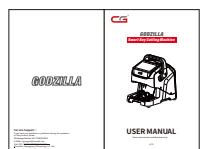
Name	Picture	Quantity	Configuration	Description
Power Adapter		1	Standard	Electrical connection tool
Built-in battery (optional)		1	Optional	Mobile power
National standard power cable(1.5m)		1	Standard	Electrical connection tool
British standard power cable(1.5m)		1	Optional	Electrical connection tool
American standard power cable(1.5m)		1	Optional	Electrical connection tool
European standard power cable(1.5m)		1	Optional	Electrical connection tool
Product inspection certificate, Packing List		1	Standard	Product factory inspection certificate, Factory packing statistics
Product manual		1	Standard	Key machine assembly / Commissioning / Instruction

2.4 Product Specifications

Input Voltage	100~240VAC
Input Frequency	50/60Hz
Maximum power	160W
Spindle speed	12000rpm
USB Port	Micro USB
Working Temperature	-20~50°C
Working Humidity	10~90%
Net Weight	13kg
Gross Weight	16kg
Machine Dimension	348*225*328mm
Packing Dimension	580*340*420mm

Godzilla host size chart



Godzilla package size chart

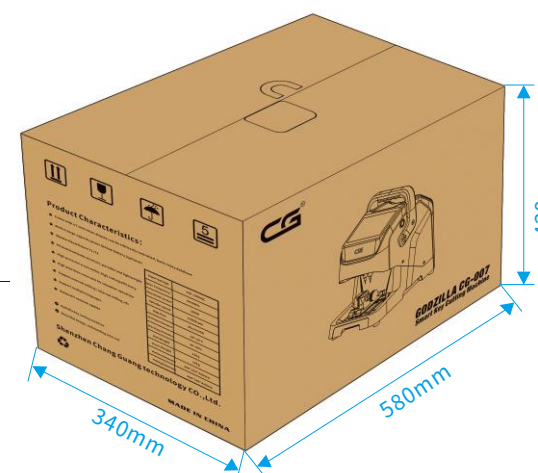

3. Installation instructions

3.1 Support plate removal

Support plate removal steps:

- (1) As shown above picture, firstly counterclockwise turn the "support plate locking screw" above the support plate until removed the screw.
- (2) Secondly counterclockwise turn the "support plate locking screw" below the support plate until removed the screw, and finally remove the support plate.

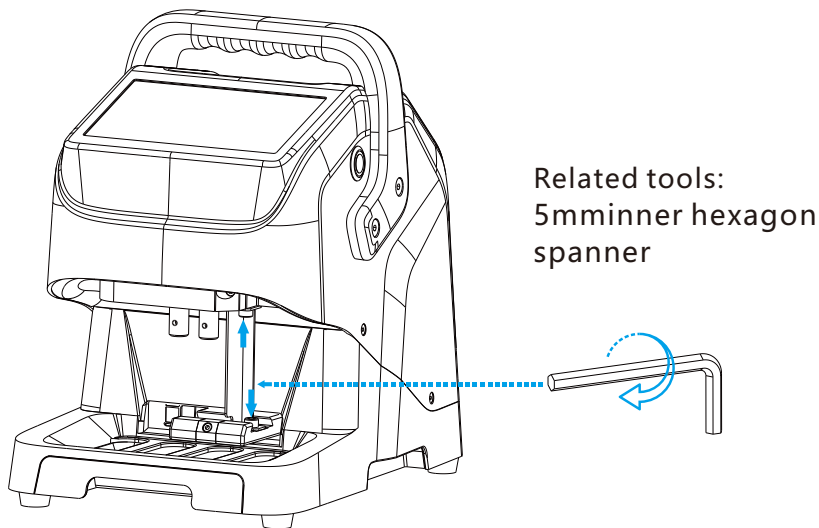

3.2 Milling cutter and probe installation

Milling cutter and probe installation steps:

- (1) As shown above picture, firstly turn counterclockwise the "milling screw", then insert the milling cutter into the mounting hole of the milling cutter, push it up to the limit, and then move it down to a certain distance (2-5mm). Finally clockwise turn the "milling screw" until the milling cutter is locked.
- (2) Refer to step 1 for the installation of the probe, and make sure that the end of the probe is higher than the milling cutter.

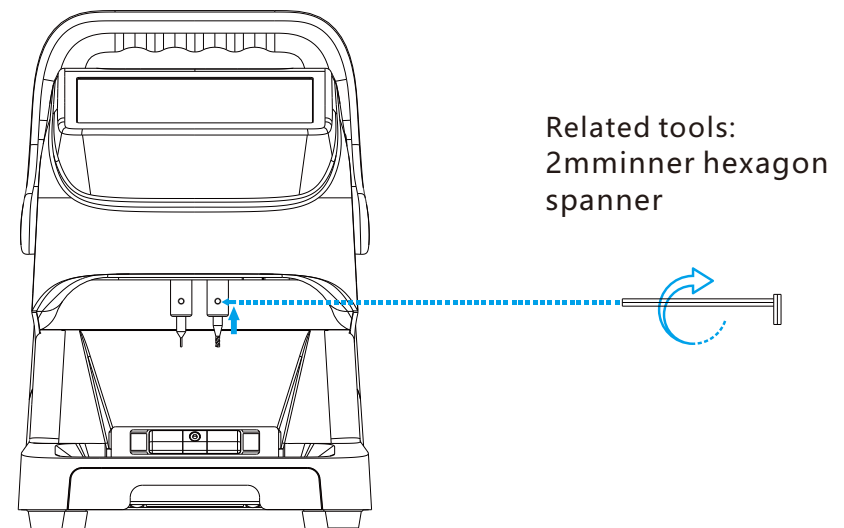

3.3 Milling cutter and probe Disassembly

Disassembly steps of milling cutter and probe:

- (1) As shown in picture, counterclockwise turn the "milling cutter/ probe top tightening screw" until the milling tool or probe is loosened, and then remove it.

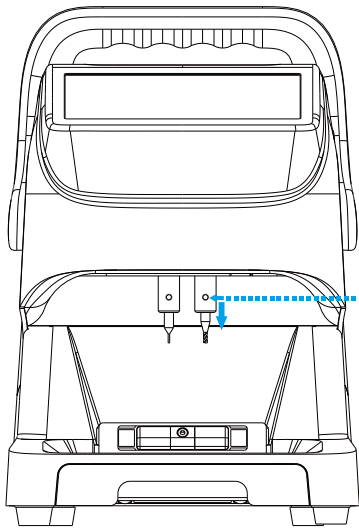

Related tools:
2mm inner hexagon
spanner

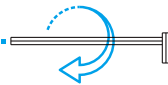

3.4 Fixture

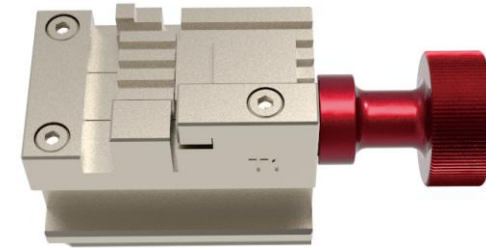

T1 Fixture

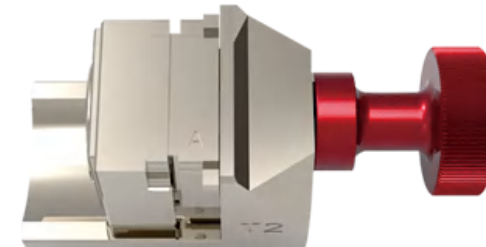

T2 Fixture

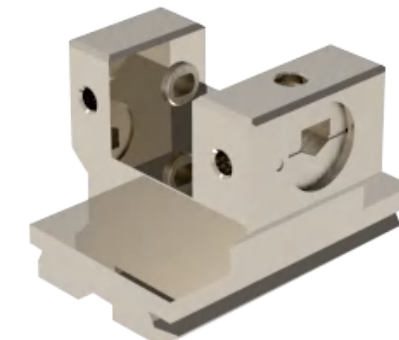

T3 Fixture

3.5 Fixture installation

Fixture installation steps:

- (1) As shown in picture, firstly loosen the "fixture locking device" to make it easier to place the fixture;
- (2) Secondly, push the required fixture into the "fixture locking device" from the right side to the limit position;
- (3) Finally, tighten the "fixture locking device" to fully lock the fixture.

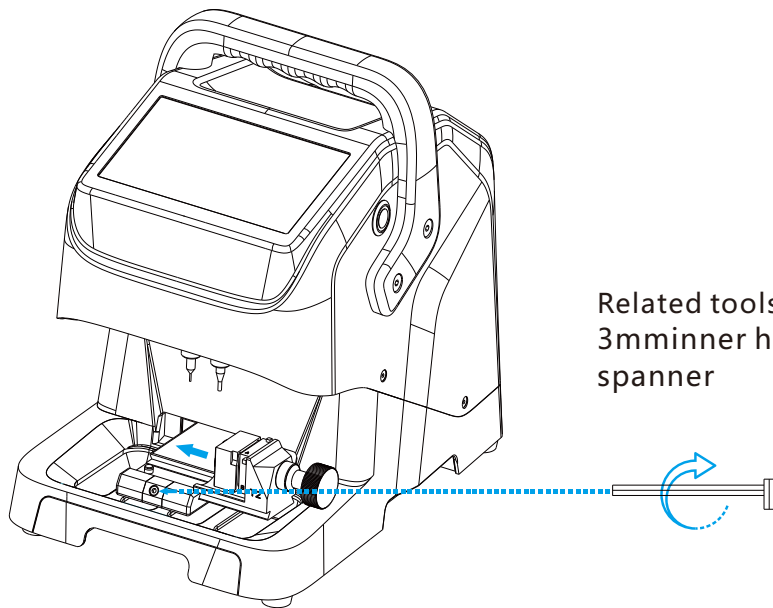

4. Operation instructions

Please calibrate for the first-time turn on the device, as follows:

4.1 Fixture offset detection

- (1) On the main interface of software, click "Device Parameters".
- (2) On the "Device Parameters" interface, click "Fixture offset detection".
- (3) On the "Fixture offset detection" interface, select "T1 fixture".

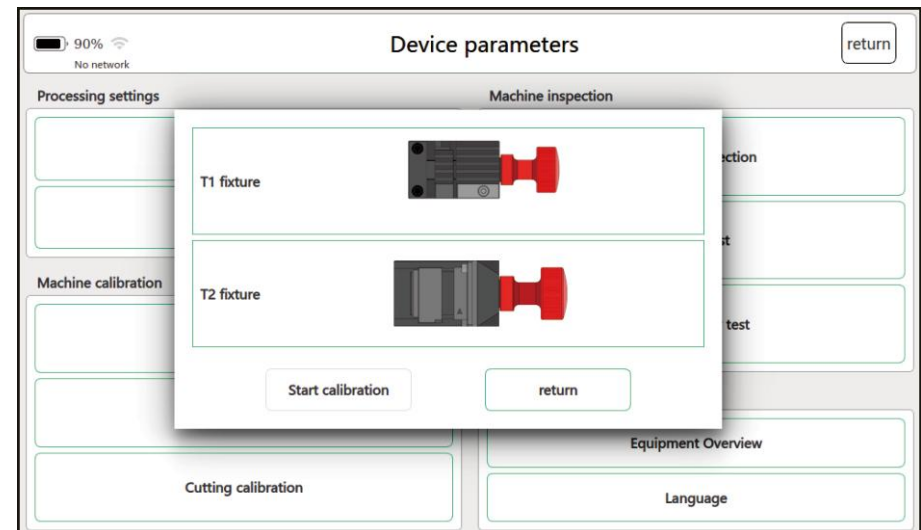

GODZILLA Key Cutting Machine-Operation instructions

- Follow the interface prompts, replace the T1 fixture and lock it, then click "Start Inspection" to enter the calibration program.
- After the machine steady stopped, click "return" to exit the interface and complete T1 fixture offset detection.

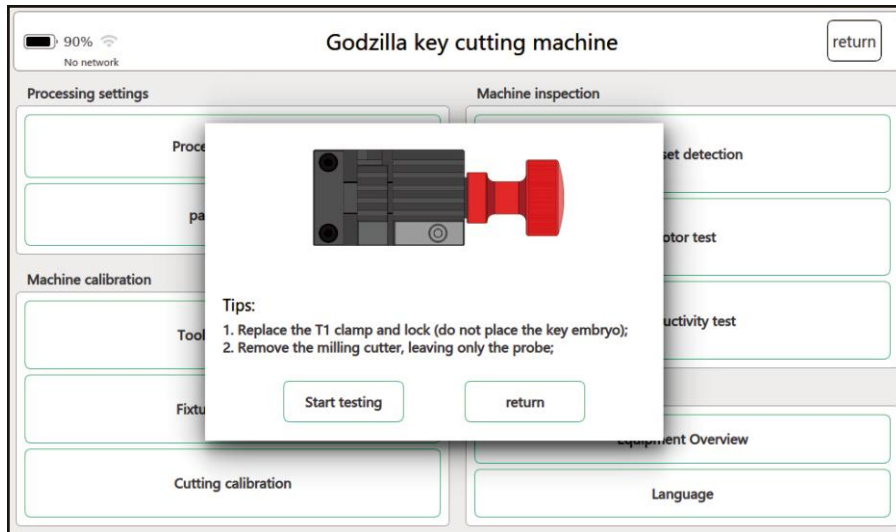

- Select "T2 fixture" in the "fixture offset detection" interface.
- According to the interface prompt, replace the T2 fixture, keep the B side upward, and then click "start detection" to enter the calibration procedure.

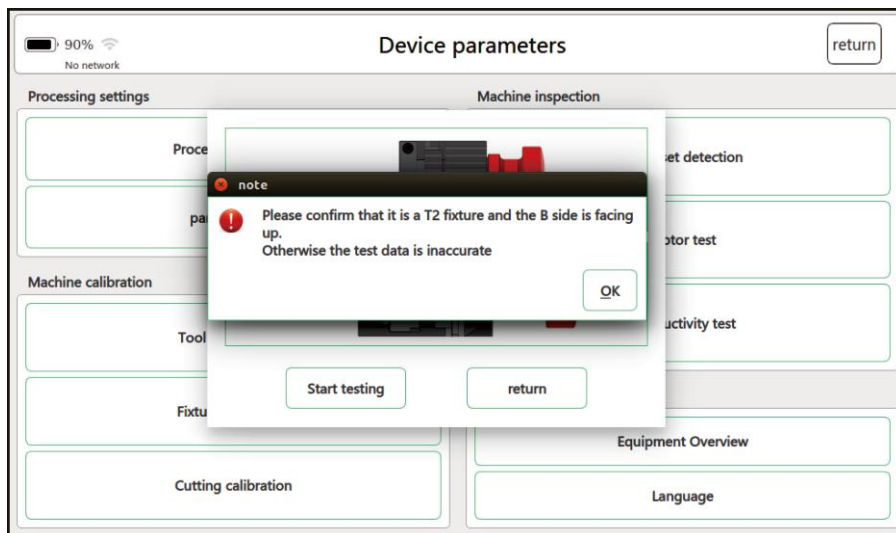

GODZILLA Key Cutting Machine-Operation instructions

- After the machine steady stopped, click "return" to exit the interface and complete T2 fixture offset detection.
- This step is already calibrated at the factory, and it is recommended to re-calibrate after replacing the new fixture (the original fixture is damaged or lost during the cutting process) (Note: After completed the calibration, the replacement between the T1 and T2 fixtures not need to re-calibrated).

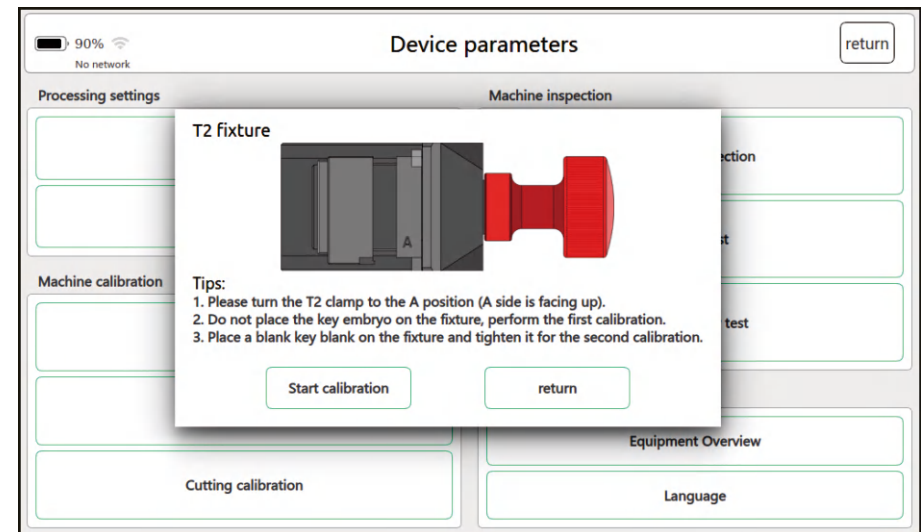

4.2 Leveling the changed height

- (1) On the main interface of the software, click "Device Parameters".
- (2) On the "Device Parameters" interface, click "Leveling the changed height".
- (3) Follow the instructions on the interface to replace the T1 fixture and lock it, and then click "Start" to enter the Leveling process.
- (4) After the machine steady stopped, you can adjust the milling cutter and the probe. When both states show green light, it is leveled.

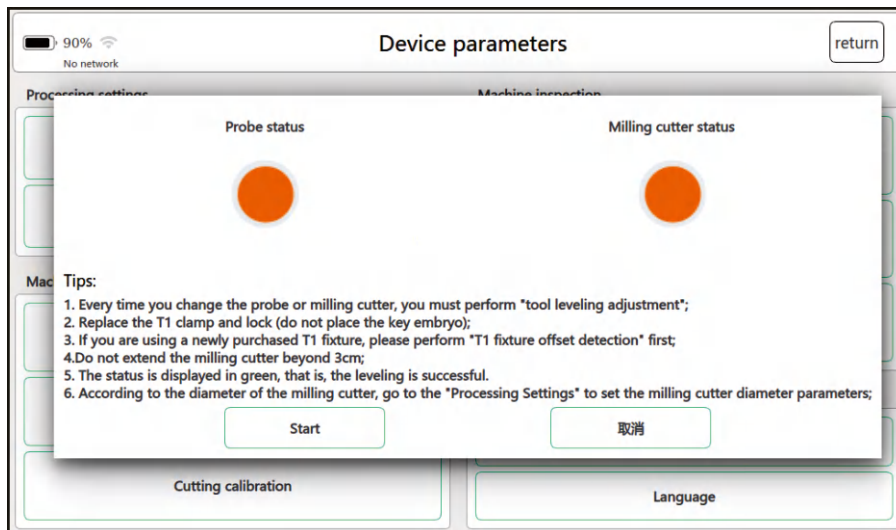

- (5) Tighten the cutter and probe, and click "Exit" to complete the leveling.
- (6) After the machine steady stopped, according to the installed milling cutter diameter, click "Processing Settings", select the corresponding milling cutter diameter on the interface depending on the actual needs, and click "Settings" to complete the setting, and then click "Close" to exit.

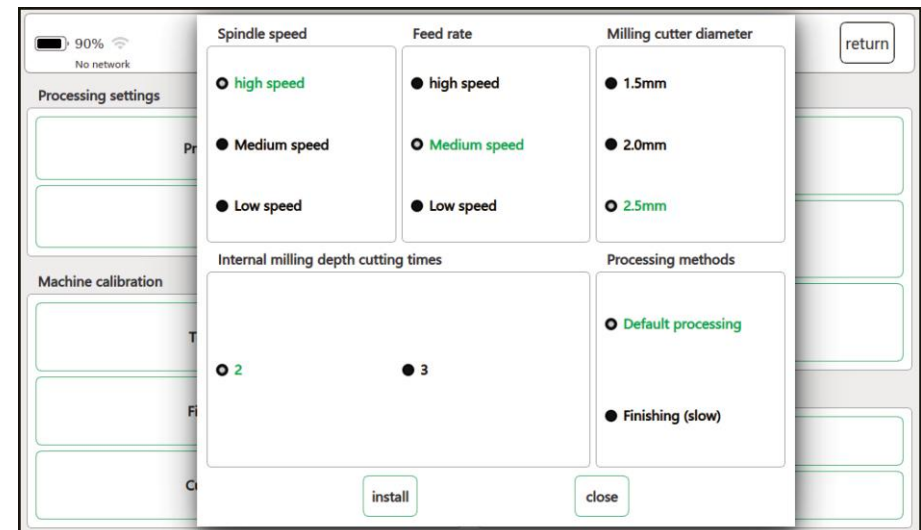

4.3 Leveling the changed height

- (1) On the main interface of the software, click "Device Parameters".
- (2) After entering the self-test page, click on "tool leveling".

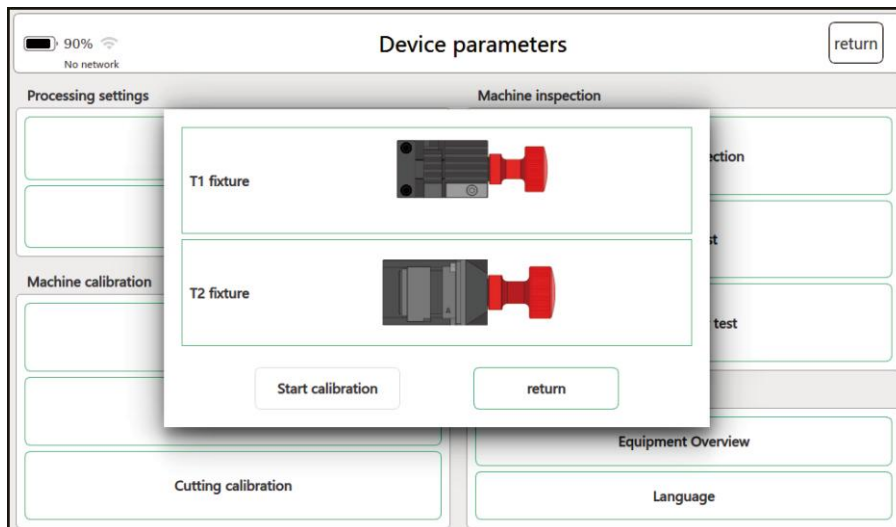

- (3) Select "T1 Fixture" in the "fixture calibration" interface.
- (4) Following the prompts, replace the T1 fixture and lock it, click "start calibration" and wait for the calibration to complete.
- (5) After the calibration is complete, click "Back".

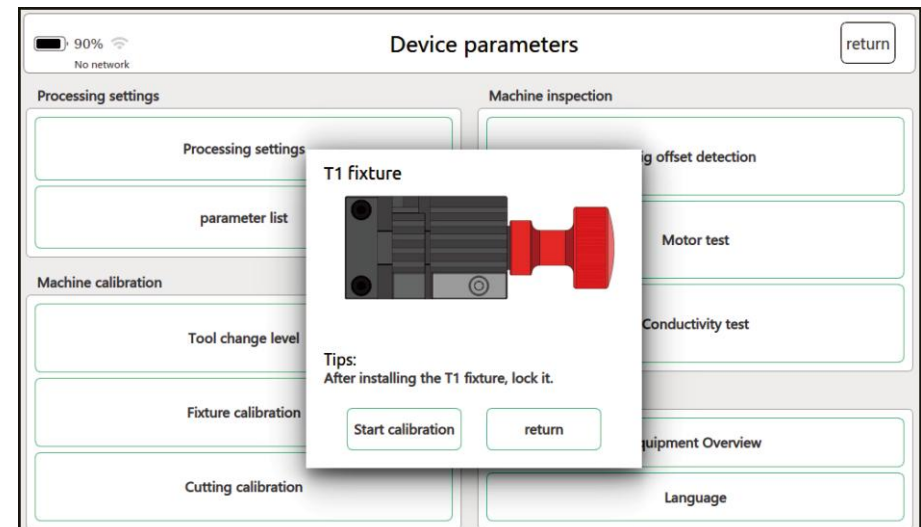

- (6) Select "T2 fixture" in the "fixture calibration" interface and then click "T2A".
- (7) Enter the calibration of the A side of the T2 fixture, replace the T2 fixture and lock it according to the prompts, rotate the fixture to the A side up, and then click "Start Calibration"
- (8) After completing the calibration, place a blank key on side A and clamp it, and click "Start Calibration" again
- (9) After completing the calibration, click "Exit" to finish the calibration of the T2 fixture A side.
- (10) Then complete the calibration of T2b, T2C and T2D in turn, and the installation interface prompts calibration.
- (11) After all four sides are calibrated, T2 fixture calibration is completed.
- (12) This step is already calibrated at the factory, and it is recommended to recalibrate after replacing the new fixture (the original fixture is damaged or lost during the cutting process) (Note: After completed the calibration, the replacement between the T1 and T2 fixtures not need to re-calibrated).

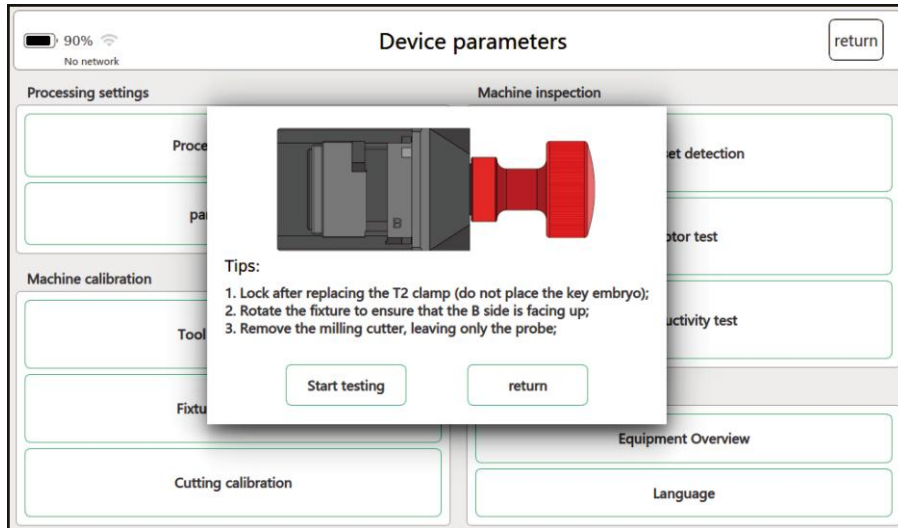

4.4 Car Database

- (1) Firstly determine the model and year of the car when copy key. On the main interface of the key cutter, click "Car Database" to enter the next page.

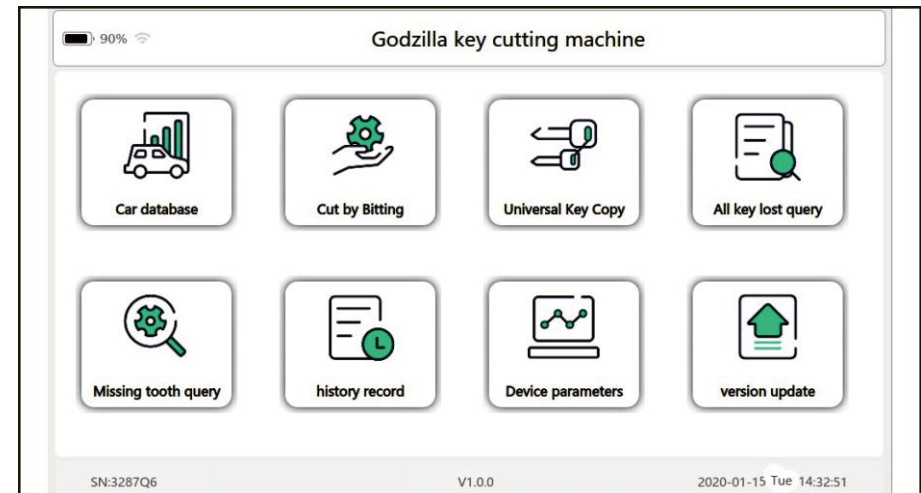

- (2) Enter the vehicle manufacturer or model in the search box, or select the model from the list, and click to enter the next page.

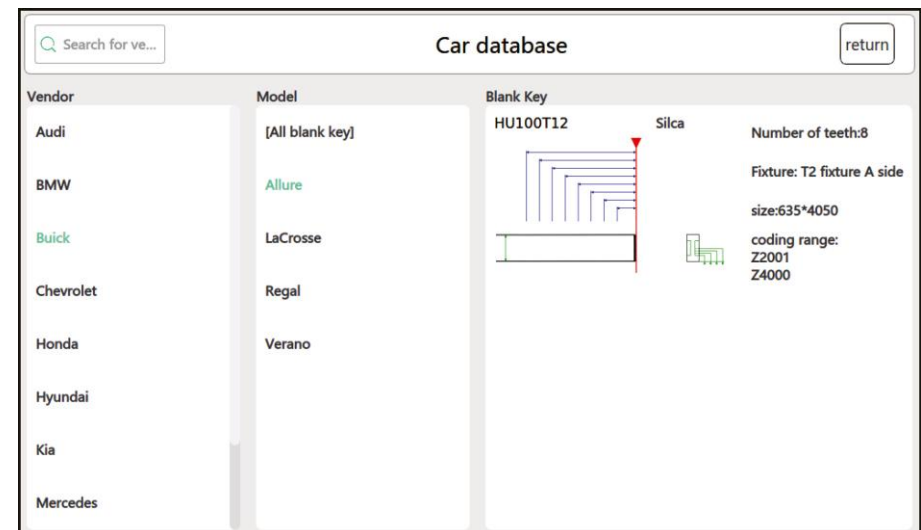

(3) Select the model and blank key, and click to enter the processing interface.

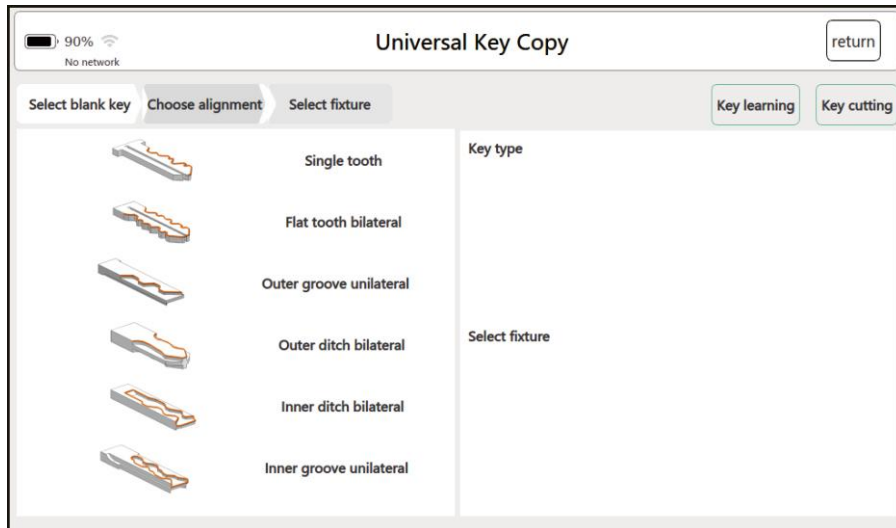

(4) Follow the prompts to properly insert the key, and click "Key Learning".
 (5) Obtain the original key tooth code. After confirmed correct, click "Key Cutting".

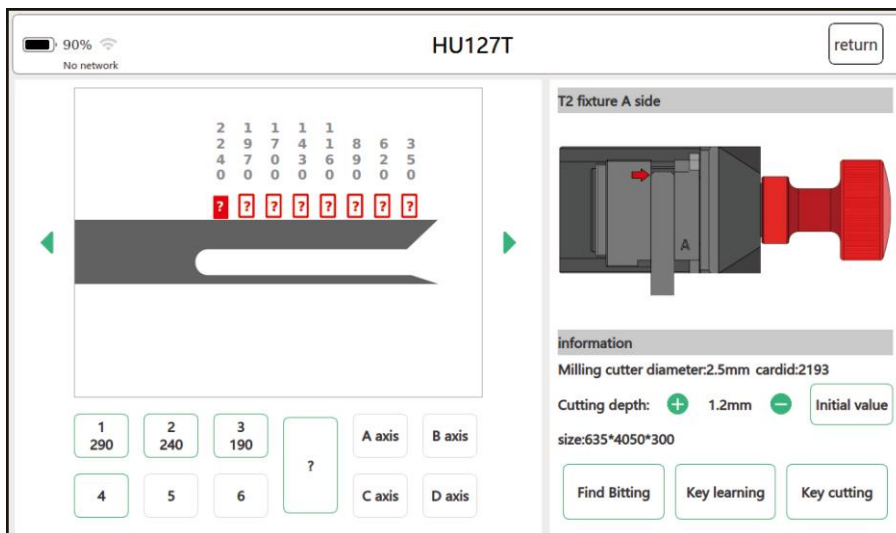

4.5 Universal Key Copy

(1) Click "General Key Copy" to enter the general key copy interface.
 (2) Click the "Select Blank Key" button and click to go to the next page.

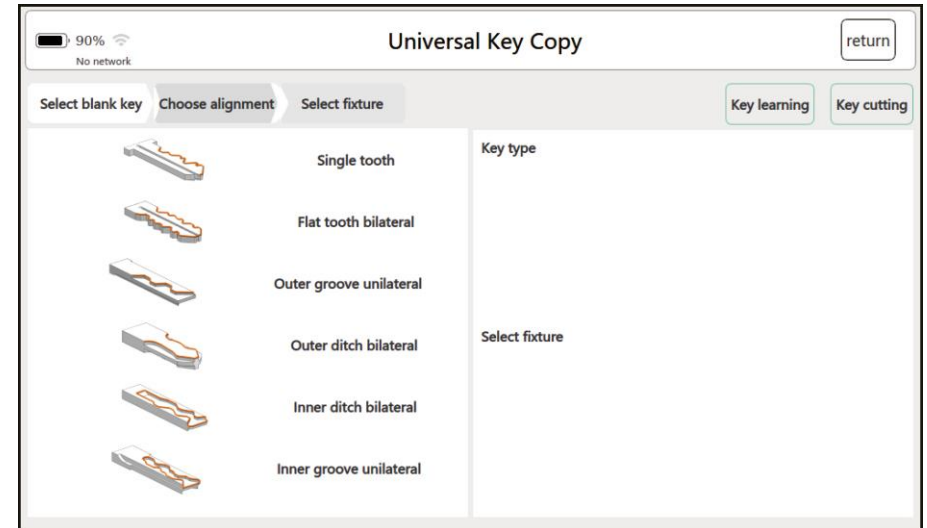

(3) Select the alignment method and proceed to the next page.

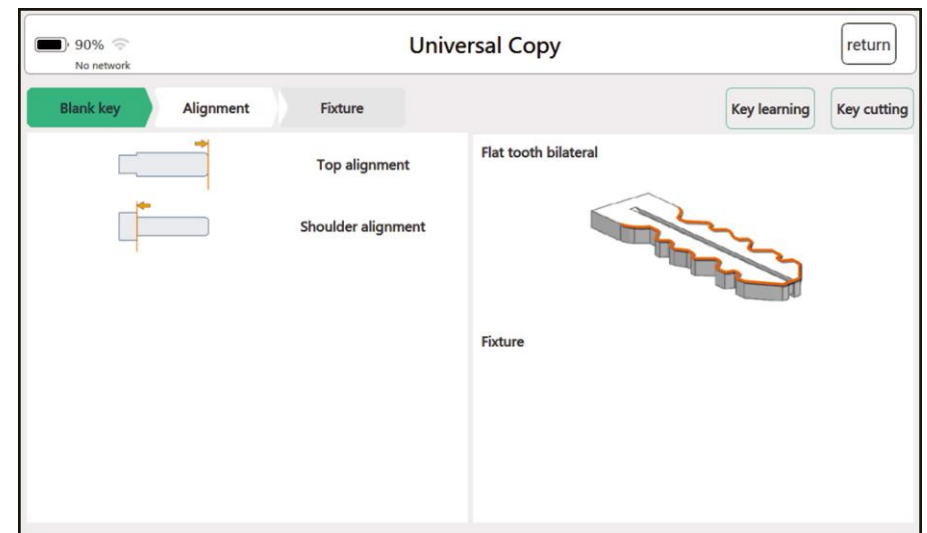

- (4) Select the correct fixture and click "Key Learning".
- (5) Obtain the original key tooth code. After confirmed correct, click "Key Cut".

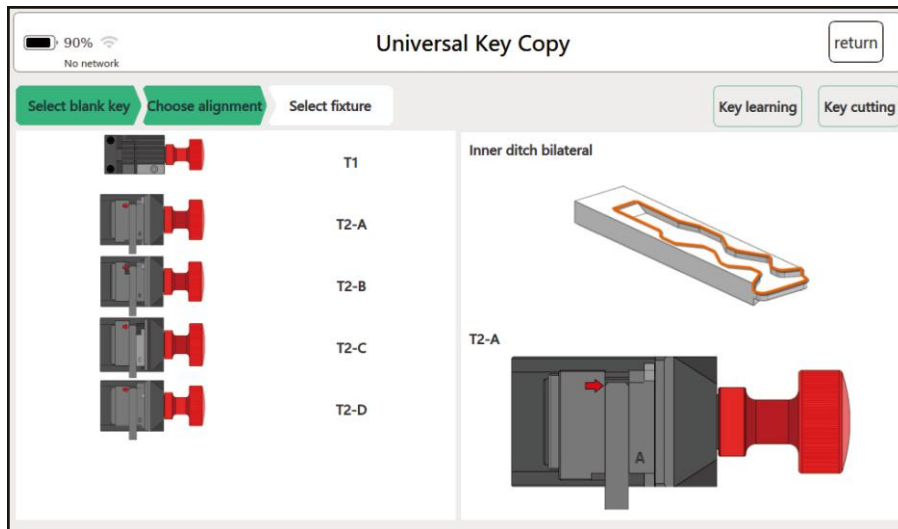

4.6 Cut By Bitting

There are two ways for using Cut By Bitting according to whether the original key is available.

The First way

There are two ways to obtain the tooth code without the original car key:

1. Get the number of teeth with a special tools.
2. Disassemble the car lock, check the lock plate to get the tooth number.

- (1) Click "Cut By Bitting" to enter the key embryo selection interface.

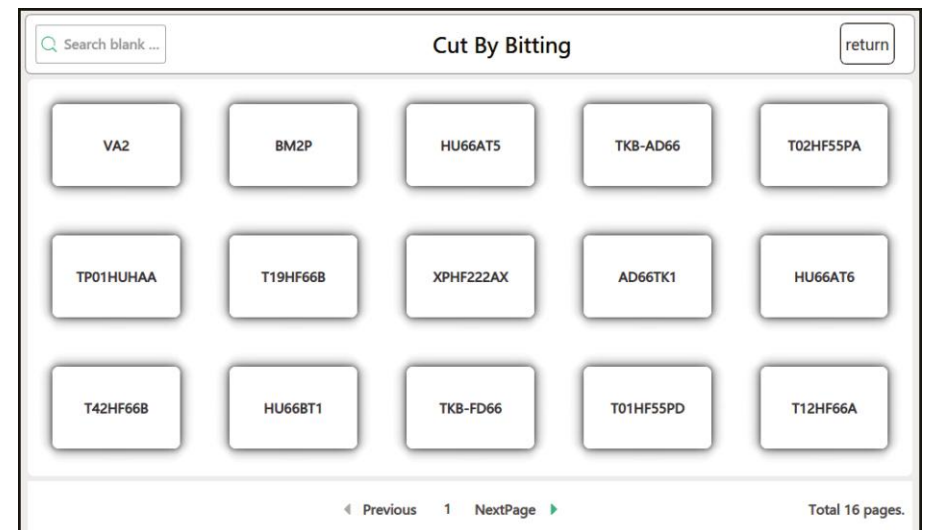

(2) Select the key type to enter the processing page.

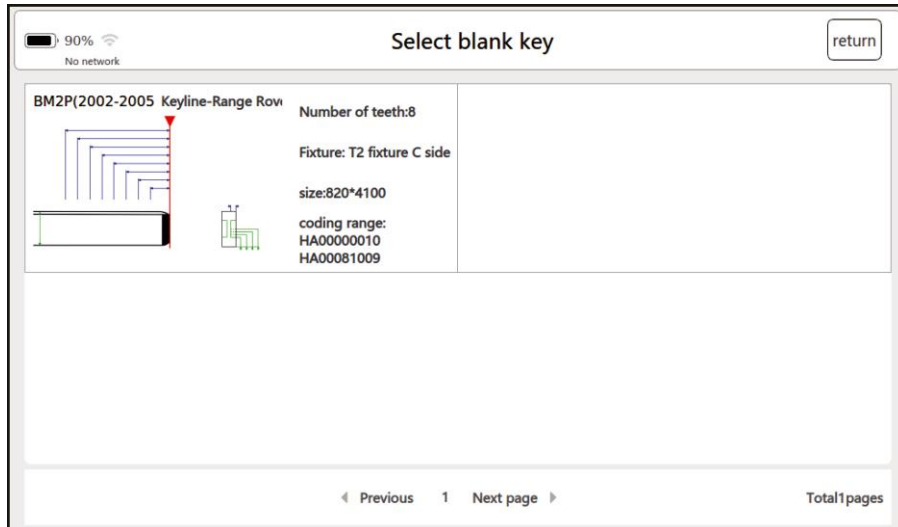

- (3) Check the relevant parameters according to the page prompts, confirm the type of fixture and adjust the position of the fixture.
- (4) Enter the known tooth profile number, click "Key Cut" after confirming.

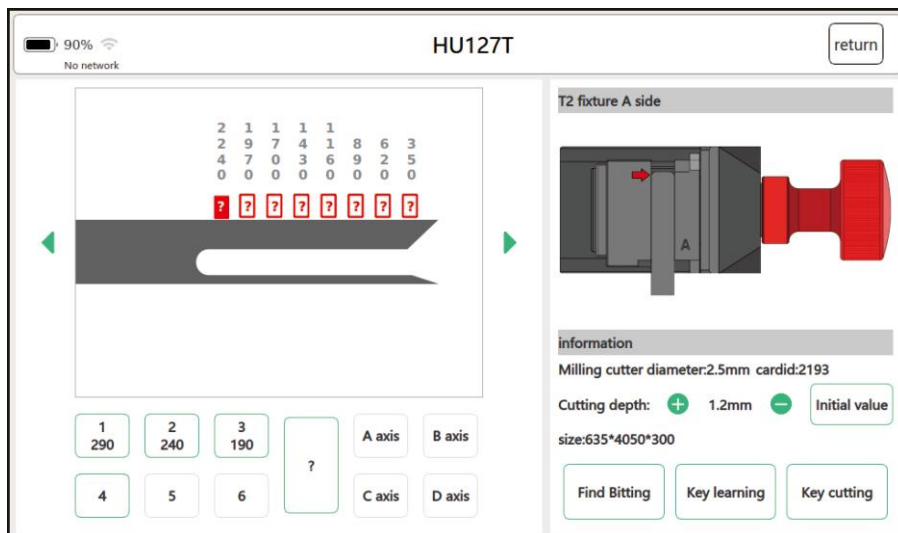

The second way

There are original car keys, keys are made by Cut By Bitting.

(1) Click "Cut By Bitting", select or enter the key

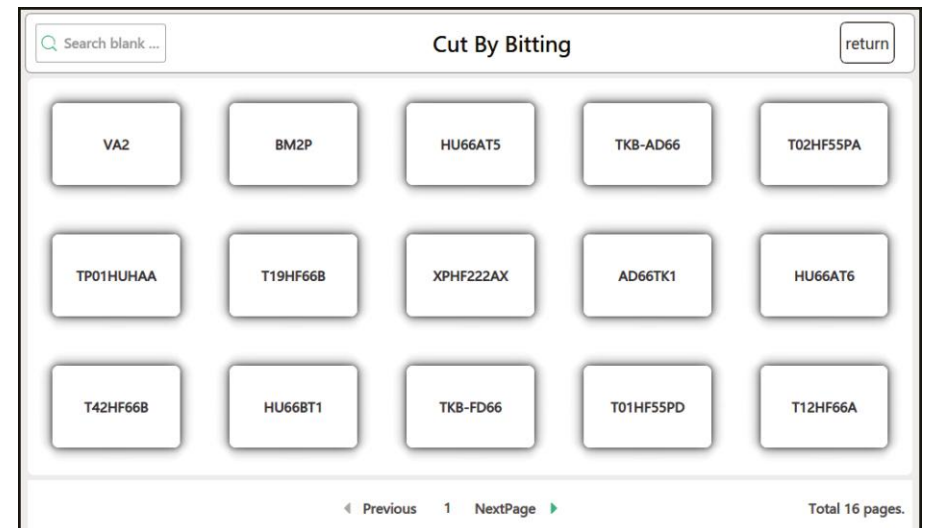

(2) Select the key type and click to enter the processing interface.

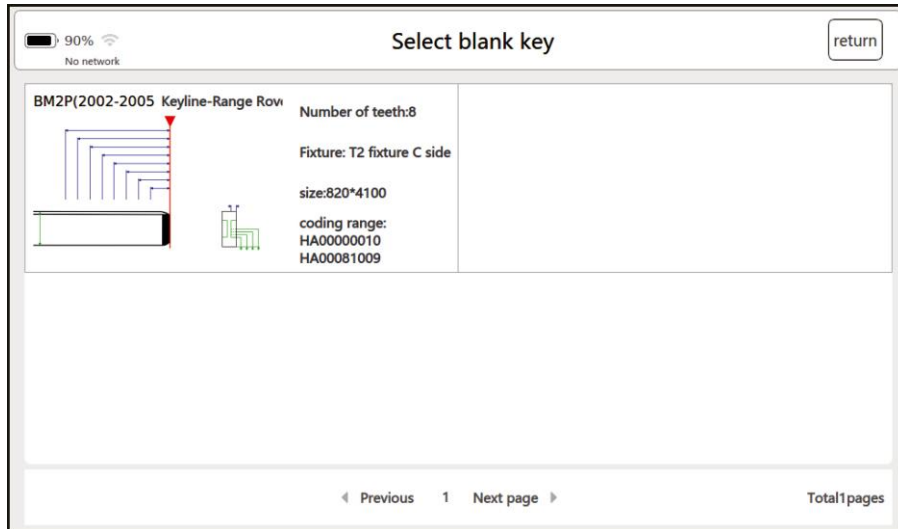

(3) Click "Key Learning" to get the original key tooth shape.
 (4) After confirming, click "Key cutting".

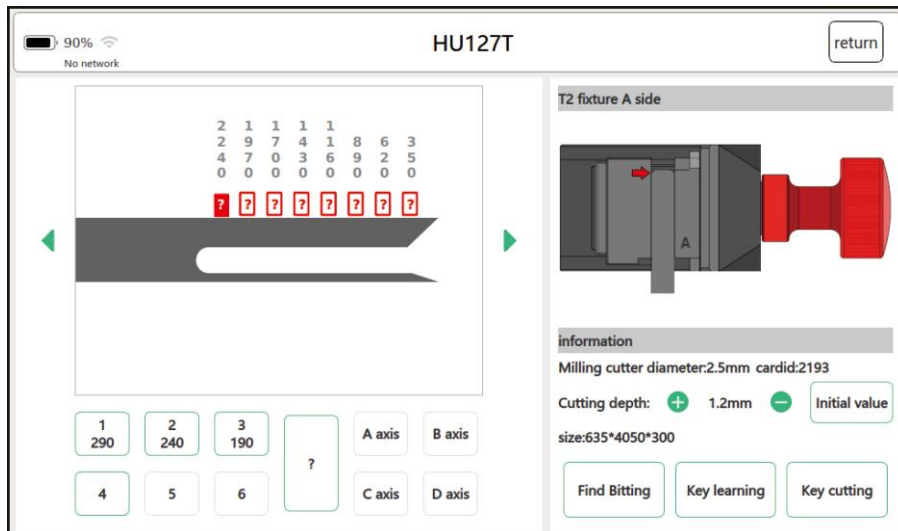

4.7 All Key Lost Query

(1) Click "All Key Lost Query" to enter the vehicle brand selection interface.

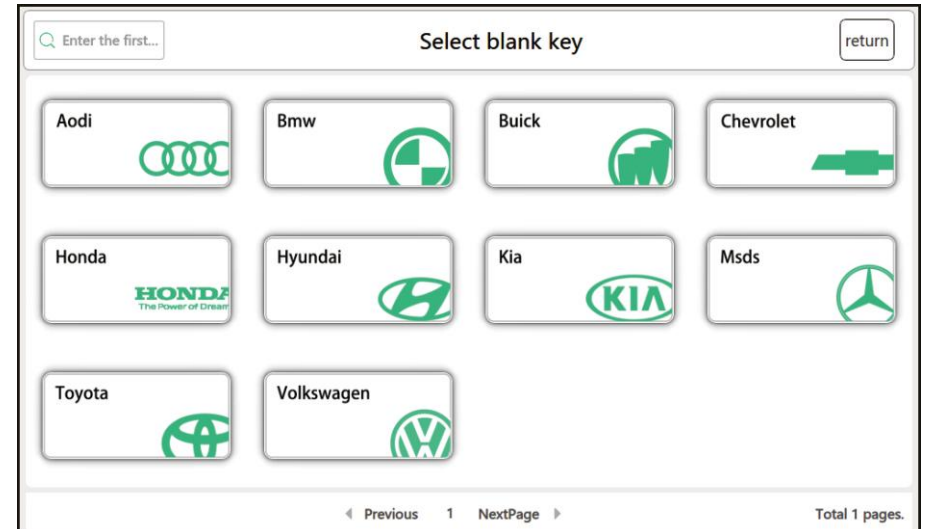

(2) Click on the selected vehicle brand, enter the key tooth code, and click "Query".

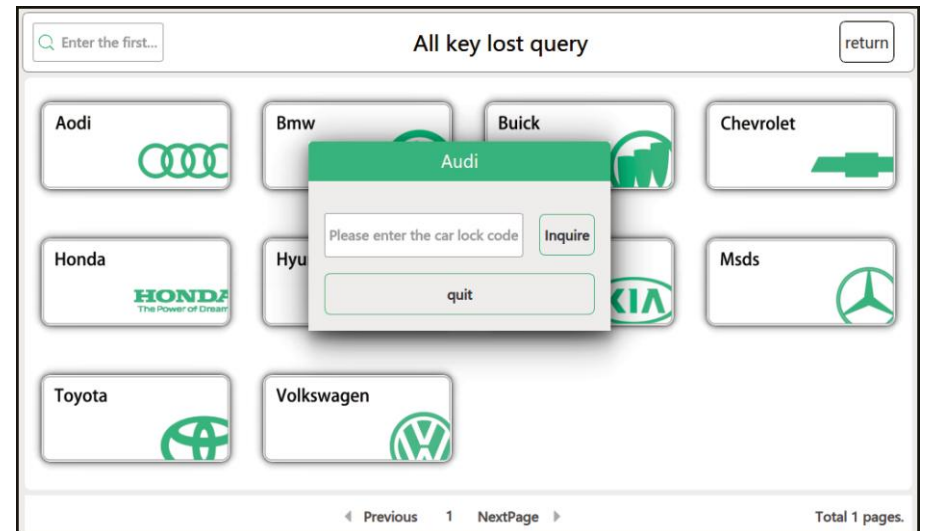

(3) Select the key serial number from the list and click to enter the processing page.

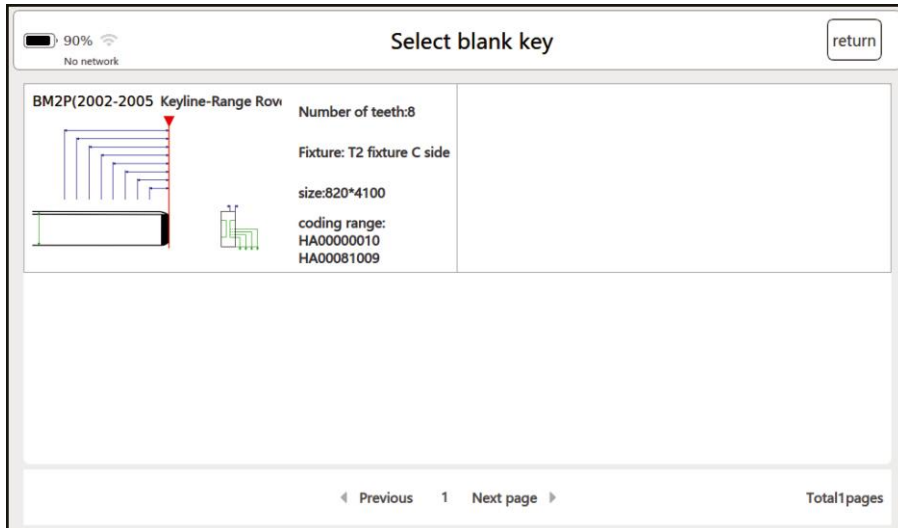

(4) The tooth code will be generated automatically.
 (5) After confirming no error, click "Key Cutting" to start processing.

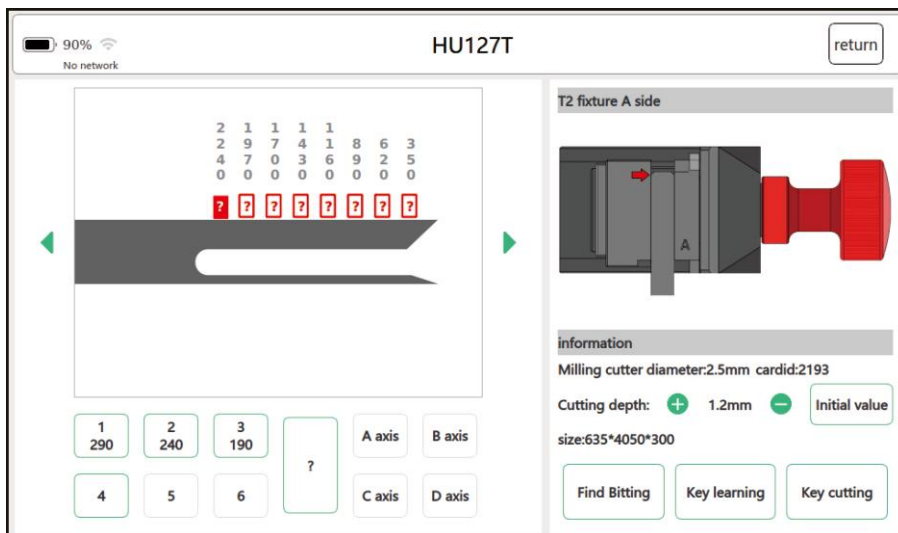

4.8 Missing Tooth Query

(1) Click "missing query" to enter the vehicle brand or model selection interface.
 (2) Select or enter the vehicle brand or model and click to enter.

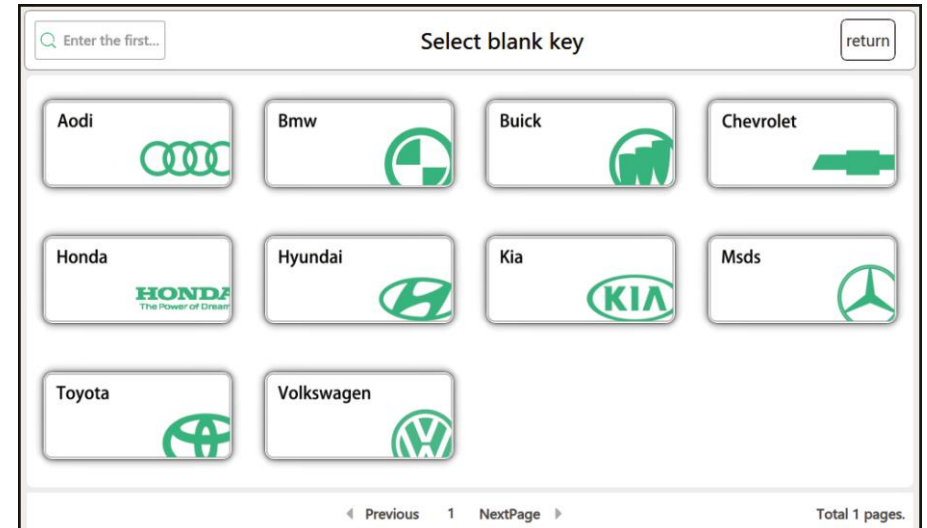

(3) Select the key embryo type and click to enter.

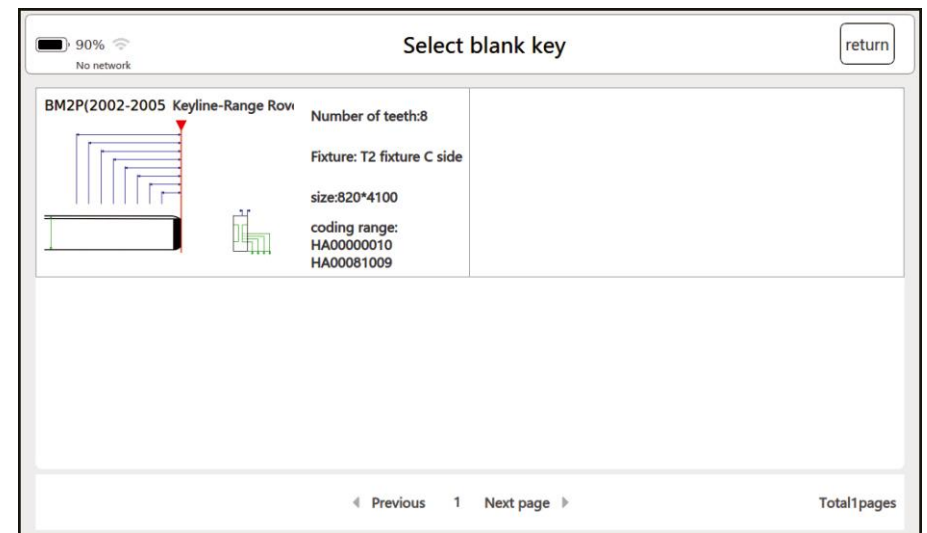

- (4) Enter the known tooth shape code. If the tooth shape code is not clear, enter "?" directly, and click "missing tooth query" after input. According to the system calculated tooth shape to code and process

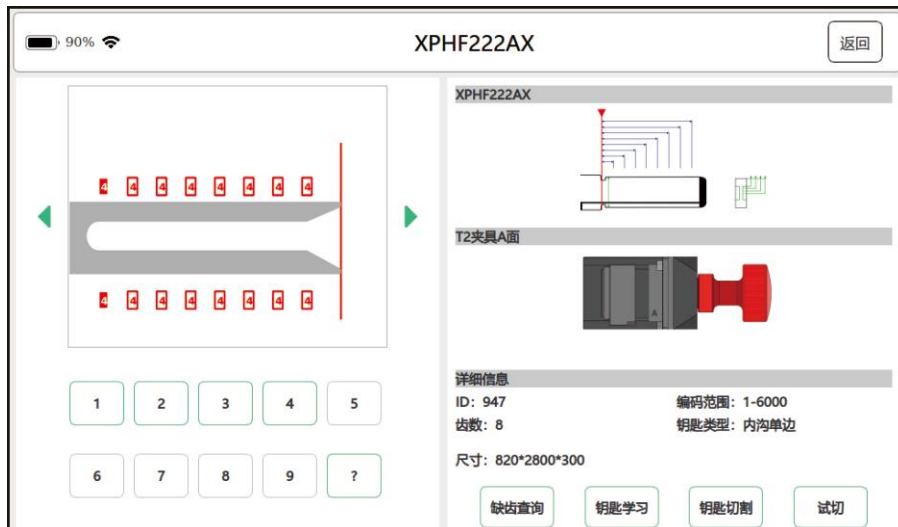

5. Online upgrade

5.1 Wi-Fi connection

- (1) On the "Main Interface" or "Version Update" interface, click the WIFI logo to enter the WIFI connection interface.
 (2) Follow the interface prompts to connect. If it is connected, the WIFI mark as

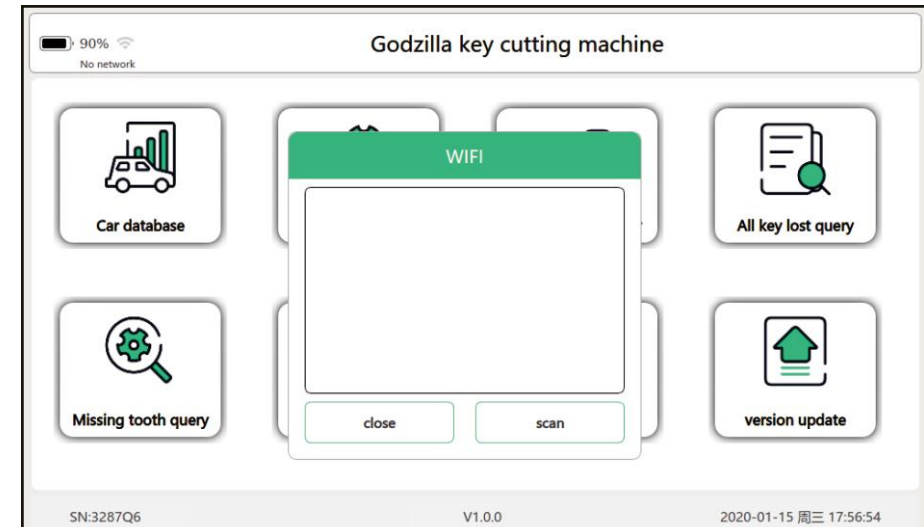

5.2 Software online upgrade

- (1) On the main interface, click " Version Update".
- (2) If the server version need update, the text will turn red, if not, it is the latest version.

Types	Local version	Server version
APP update	V1.0.0	V1.0.0
Firmware update	V1.0.0	V1.0.0
FPGA update	V1.0.0	V1.0.0
Database update	V1.0.0	V1.0.0

- (3) Click "APP Update" and click "Yes" in the pop-up dialog box to download and install the latest version.

Types	Local version	Server version
APP update	V1.0.0	V1.0.0
Firmware update	V1.0.0	V1.0.0
FPGA update	V1.0.0	V1.0.0
Database update	V1.0.0	V1.0.0

- (4) If prompted as above shown when updated fails, you can update again after restarting.

Types	Local version	Server version
APP update	V1.0.0	V1.0.0
Firmware update	V1.0.0	V1.0.0
FPGA update	V1.0.0	V1.0.0
Database update	V1.0.0	V1.0.0

5.3 Firmware upgrade online

- (1) On the main interface, click "Update Version".
- (2) If the server version update, the text will turn red, if not, it is the latest version.
- (3) Click "Firmware Update" and click "Yes" in the pop-up dialog box to download and install the latest version.
- (4) After completed upgrade the firmware, restarts the machine to apply the update.







5.4 Database online upgrade

- (1) On the main interface, click "Update Version".
- (2) If the server version update, the text will turn red, if not, it is the latest version.
- (3) Click "Database Update" and click "Yes" in the pop-up dialog box.
- (4) Wait for the device offline data packet download to complete.
- (5) After the database is updated successfully, click "OK" to complete the upgrade.

6. Maintenance

6.1 Maintenance instructions







The following explains how to maintain the equipment and the necessary precautions.

-  **Using a soft cloth or a mild glass cleaner to clean the LCD touch screen.**
-  **Do not use abrasive cleaners or detergents on the touch screen and all parts of the machine.**
-  **Dry your hands before using the screen. If the touch screen times overtime, or if you tap the screen with a wet finger, it may affect the touch sensitivity.**
-  **Keep the key cutting and processing area clean, otherwise debris and impurities will corrode the machine parts and reduce the accuracy of key processing.**
-  **Do not wash the machine and its components directly with water, and do not use a damp cloth to wipe the machine to prevent the machine from leaking electricity or rusting metal parts.**
-  **Do not drop the equipment or subject it to severe impact.**
-  **Do not replace the battery yourself or use a charger that is not included in the package.**

7. Warranty

Shenzhen Changguang Technology Co., Ltd. (hereinafter referred to as the "Company") promises to be the original retail buyer of this product, within one year from the date of delivery (if there is no transaction certificate, the factory date recorded in the company shall prevail), if Under normal use conditions, the product or accessory has defects in technology or materials that cause the equipment to fail. Based on the transaction certificate, the company will provide you with repair or replacement services based on the situation.

This warranty does not apply to:

-  **Failure to use the machine in accordance with the instructions and cause the machine to malfunction.**
-  **Damage caused by self-repair or modification.**
-  **Failure of the machine due to drop, impact or improper voltage.**
-  **Damage to the machine due to unresistible factors.**
-  **If it is used in a harsh environment or on a vehicle or a ship for a long time, causing machine failure or damage.**
-  **The casing and protective cover are dirty and worn out due to daily use.**